



REQUEST FOR QUOTE FAX COVER SHEET

TO: KEB Industries, Inc.
ATTN: SALES
FAX: (440) 953-9209

FROM: _____
COMPANY: _____
PHONE NUMBER: _____

MACHINE MAKE & MODEL: _____

COLLET/GUIDE BUSHING REQUIRED: _____

*All Counter Bore Collets are smooth bore.
**Duplicate this sheet prior to use.

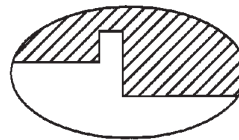

NOTE:
.015 X .010 Deep Undercut
on all Bores

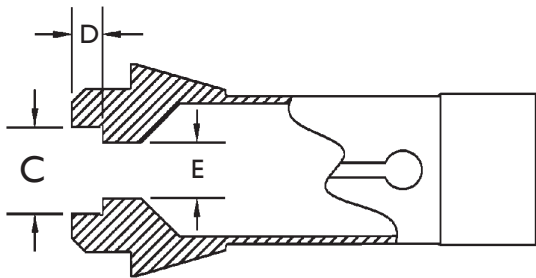

COUNTER BORE

C= _____ D= _____ E= _____

Additional Bore:

C2= _____ D2= _____ E2= _____

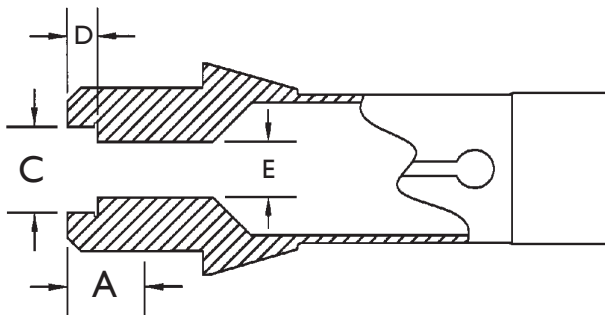

EXTENDED NOSE COUNTER BORE

A= _____

C= _____ D= _____ E= _____

Additional Bores:

C2= _____ D2= _____ E2= _____

C3= _____ D3= _____ E3= _____

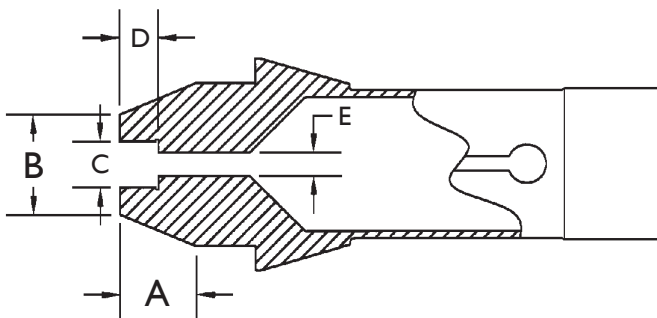

EXTENDED NOSE TAPERED COUNTER BORE

A= _____ B= _____

C= _____ D= _____ E= _____

Additional Bores:

C2= _____ D2= _____ E2= _____

C3= _____ D3= _____ E3= _____